

## Flexible Rod Belts

Multi-tier spiral conveyor belts.

Flexible Rod belts are designed primarily for multi-tier spiral conveyors commonly used in the food industry. With the ability to side flex, the belt can also be used for conveyors arranged to go around obstacles.

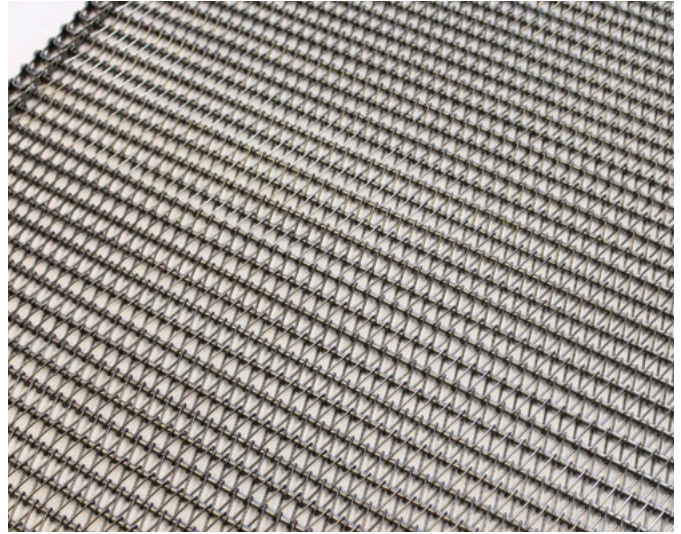

### Typical Applications

- ✓ Transport
- ✓ Drainage
- ✓ Cooking
- ✓ Freezing
- ✓ Heating
- ✓ Elevating
- ✓ Drying
- ✓ De-Elevating
- ✓ Cooling



### Advantages

Whether used on spiral or straight conveyors, the belt is particularly suitable for cooking, cooling or freezing products such as bread, pastry, vegetables, potatoes, fish and meat. It can also be used for blanching vegetables, proofing dough, drying, baking or pasteurising.

Flexible Rod belt is constructed of cross rods, with collapsing links each side. For improved product support, the rods may be overlaid with a spiral mesh. Flexible Rod belts can also be supplied with a link in the centre of the belt width to decrease its turning radii, as well as side guards to prevent product spillage.

## Specifications

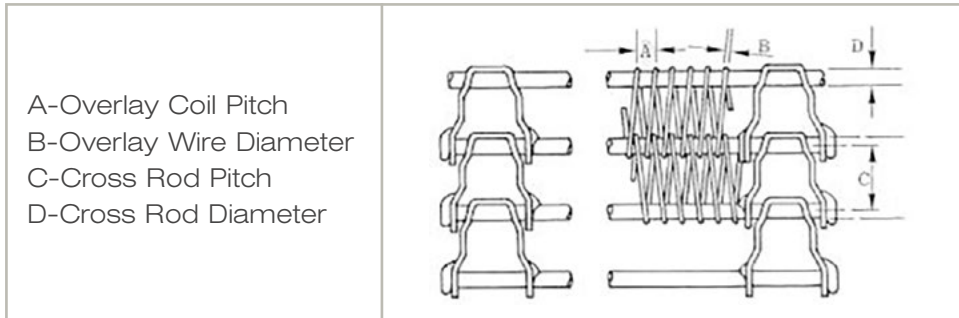

Available belt pitches:	19.05mm or 27.43mm
Minimum width:	152mm
Maximum width: (Larger widths available for straight running applications)	1016mm (for turn applications)
Minimum turn ratio:	2.2:1*
Overlay wire Diameters:	1.2mm, 1.4mm, 1.6mm, 2.0mm

\*Consult our Technical Sales for applications requiring a smaller turn ratio.

